

Piston Pin Bore Diameter

NOTE: Refer to the appropriate Section 303-01 for the specification.

1. **NOTE:** Piston and piston pins are a matched set and should not be interchanged.

Measure the piston pin bore diameter in 2 directions on each side. Verify the diameter is within specification.

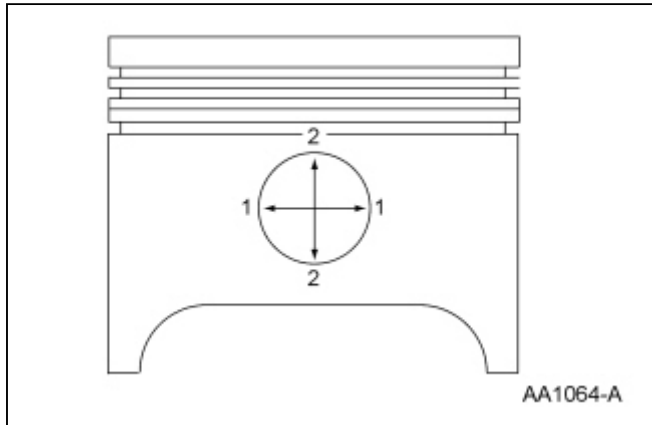

AA1064-A
